

Floor Grinder C-BHF-125

Order-no.: 50015991

Floor Grinder – Precise grooves for underfloor heating systems!

Our Floor Grinding Machine has been specially developed for cutting grooves in screed floors and for installing plastic pipes for central heating systems.

Compact, robust and easy to use – ideal for tradespeople and installers who want to work quickly and precisely.

Your advantages at a glance:

- Accurate manual depth adjustment
- Integrated dust extraction via the blade guard for clean working
- Multiple swivel wheels for optimum manoeuvrability, even in confined spaces
- Minimum radius of the slotted loop approx. 60 mm – ideal for tight pipe routing
- Centre of gravity directly above the blade shaft for stable guidance
- Extendable guide bar (right) for comfortable handling
- Guide pin for parallel slots
- Maximum working width: 18 mm

Technical data		C-BHF-125
Type		Milling/Grinding Machine
Max. cutting depth	mm	25
Max. Blade-Ø	mm	125
Bore hole of blade	mm	22,23
Drive motor	kW/ V/ Hz	4,5 / 400 / 6
RPM	r/min	2.850
Dimensions (L/W/H)	mm	1000 / 500 / 600
Weight	kg	60

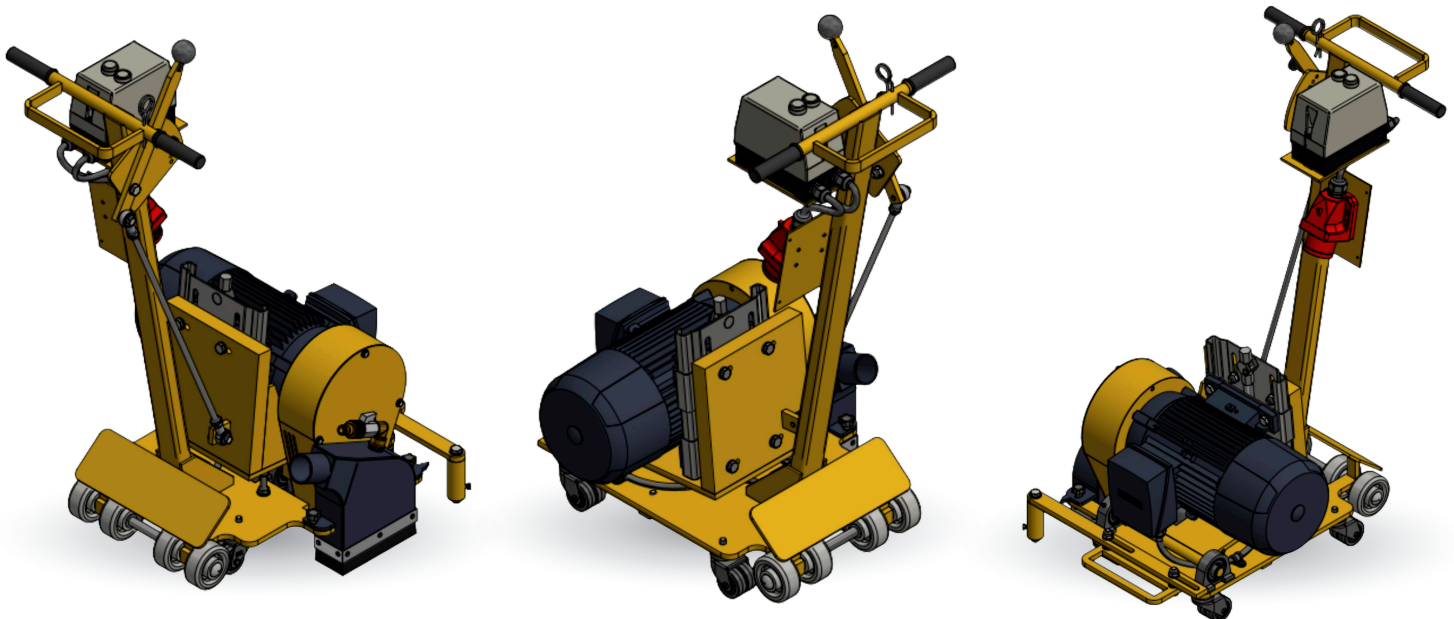
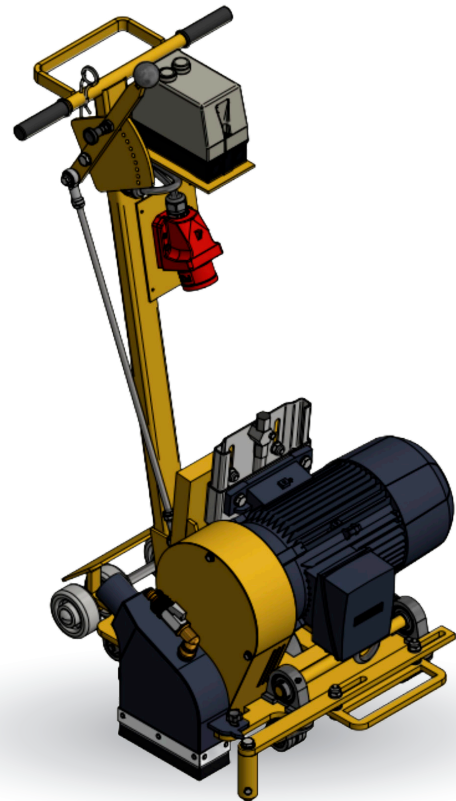

Subject to technical and optical changes and further developments.